

# WILDCATTING



CAT. NO.  
26-3067

**Radio Shack**

**TRS-80**



**COLOR  
COMPUTER**

TM

*Wildcatting Program:*  
© 1980 The Image Producers, Inc.  
*Licensed to Tandy Corporation.*  
*All Rights Reserved.*

This applications software for the TRS-80 Color microcomputer is retained in a read-only memory (ROM) format. All portions of this software, whether in the ROM format or other source code form format, and the ROM circuitry, are copyrighted and are the proprietary and trade secret information of Tandy Corporation and/or its licensor. Use, reproduction or publication of any portion of this material without prior written authorization by Tandy Corporation is strictly prohibited. The license for using this software is printed in the back of this manual.

*Wildcatting Program Manual:*  
Copyright, 1981. The Image Producers, Inc.  
*Licensed to Tandy Corporation.*  
*All Rights Reserved.*

Reproduction or use, without express written permission from Tandy Corporation, of any portion of this manual is prohibited. While reasonable efforts have been taken in the preparation of this manual to assure its accuracy, Tandy Corporation assumes no liability resulting from any errors or omissions in this manual, or from the use of the information obtained herein.

Wildcatting is an exciting, financially risky search for oil hidden below the earth's surface. If you make wise investments you may become a rich oil tycoon; if you don't, you may find yourself working on the rigs to pay your drilling debts!

What You Need:

A TRS-80 Color Computer with at least 16K RAM

A color television

Joysticks (optional)

## **Loading Instructions**

1. Before inserting or removing a Program Pak™ ROM cartridge, make sure the computer is OFF. Failure to do so could result in damage to the Program Pak.
2. Connect the Color Computer to the television set and move the antenna switch-box control to Computer (or Game). See your TRS-80 Color Computer Operation Manual for further details regarding connections.
3. If joystick controllers are being used, plug them into the jacks located on the back of the computer.
4. Insert the Wildcatting Program Pak, label side up, into the slot located on the right side of the computer. Press firmly until it securely engages, but do not force it.

5. Turn on the television and tune it to channel 3 or 4 (whichever is least active in your area).
6. Turn on the Color Computer. You may have to adjust the focus on the television or press the Reset button (located on the back of the computer) to obtain a clear picture.

### **Note the Following:**

As you progress through this manual, keep in mind that any direction mentioning the “button” refers to the button on the joystick controller. If you are not using joysticks, press the space bar on your keyboard in place of the button. Likewise, when you need to maneuver around the screen, the arrow keys perform in place of the joysticks.

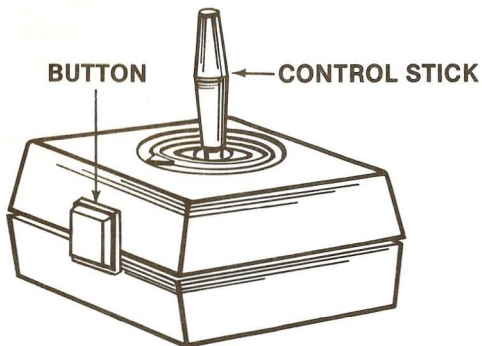

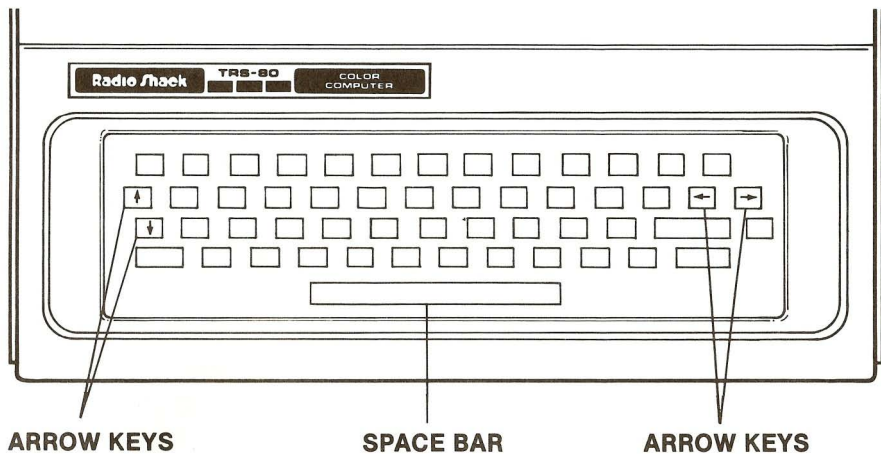

## Playing the Game

After loading the Wildcatting cartridge, select and enter the number of players (1-4).

Up to four players can play Wildcatting, using either the keyboard or joystick controls. You must tell your computer if you are using joysticks. Press the **Y** key for Yes, **N** for No. If you are using joysticks, use the left joystick for a single player, and both for a two, three or four player game. In a three player game, players 1 and 3 alternate using the left joystick, and player 2 uses the right joystick. In a four player game, player 4 uses the right joystick also.

Now, type the names of the players, pressing **ENTER** after each. (Note that the ← cannot be used to correct typing errors.) When all names have been entered, and the joystick option has been decided, the scoreboard will show the names of the players and their assets, starting at \$0.

The player indicated by the diamond symbol ( < > ) is the first to begin the search. Press the button (or space bar) to see the oil field. The field will be blank until a site is chosen. Use the joystick (or arrows) to move the land marker to any location that has not been drilled. The X and Y coordinates at the bottom of the screen indicate the current horizontal and vertical placement of the marker. Next, press the button to see the surveyor's report for the spot you have chosen.

The surveyor's report serves as an important investment guide. At a glance, it shows the probability of striking oil on the location you have selected, the drilling cost per meter and the tax you will pay on the property every week. Consider these factors carefully to determine if an investment in this property is likely to be profitable.

For example, the lower the percentage rate, such as 25%, the lower the probability of striking oil; the higher the percentage rate, such as 94%, the greater the probability of striking oil. Keep in mind, though, that the percentages are based on *probabilities*, so even a 94 percentage rating is no guarantee when searching for oil! In addition to the probability percentage, the costs involved may help you make the decision. A very expensive drilling cost and/or high taxes may detract from the initial profitability factor.

If you decide to take a chance and drill a well, move the blinking cursor over the Y (Yes) using the joystick or arrow keys, and press the button (or space bar). If you think the risk is too great, place the cursor over the N (No) and press the button. The next player, indicated by the diamond (◇), may then continue the search. When the choice is made to drill, the site appears on the screen. Proceed by pressing the button repeatedly. This drives the drill through the Earth's layers with the following possible results:

### **Strike It Rich!**

With a whoosh and a roar, a gusher will erupt, flowing with rich, dark oil which yields varying degrees of profit.

### **Strike Oil!**

Quite often, the well you drill will produce a smaller amount of oil than it would if it were a gusher. These are average wells and can add or detract from your profit, depending on the other cost factors.

### **Dry Hole!**

The worst possible fate of drilling is hitting a dry hole containing no oil whatsoever. When this occurs the best course of action is to sell the property immediately (as explained later).

**Note:** If you do not complete the drilling process on a well, it will be automatically recorded in your portfolio of transactions as a non-income producing property.

## Color Code

Wells that have been chosen are marked on the map using the colors included in the color bar (at the bottom left corner of the screen). White markers, as shown on the right end of the bar, represent sites with a 25% probability of holding oil; pink markers (the first color on the left in the bar) indicate a 94% probability of striking oil. The colors between represent the scale of probabilities between 25% and 94%.

The color code of a well site is unknown until after it has been chosen by a player. The next step after choosing a site is to have a look at your portfolio, which shows your weekly transactions. To do this, press the button on your controller.

## Check Your Income

Examine your financial condition. Keep an eye on the weekly yield of each well. Good wells often take a week or two to become profitable, due to drilling expenses and taxes. Hold on and watch the money roll in! Sometimes wells run out of oil. (Natural resources aren't endless, after all!) When a depleting well is costing more than it produces, sell it. Dry holes, which may occur even in the center of an oil site, never produce income and should be sold.



## Selling

After looking over your holdings, decide which wells to sell and which to keep. To sell, position the cursor to the left of the data for the well and press the button. The property will instantly be sold for 50% of the original cost. You may sell more than one well during a turn. When you do not wish to sell any more wells, place the marker in the NEXT PLAYER box in the bottom left corner of the screen and press the button. This indicates the completion of your turn.

## Scoring

To see the scores after each 13 week period of play, press the button. A color coded map will be constructed on the screen to indicate where the oil deposits were located during that game.

Now press any keyboard key (except Shift ) and you will see each player's portfolio of transactions for the 13 week period just concluded. They are displayed, in player order, by pressing a keyboard key when you are ready to look at the next player's transactions. After displaying the last player's transactions, press any keyboard key (except Shift ) and you will see the total income figures for all players for the current game, and then the accumulated totals for all players for the entire period of play.

## Playing Again?

At the end of each 13 week period, you are given the choice of continuing with the same players, or changing players. The screen displays the message,

SAME PLAYERS? (Y-N)

If you choose to continue as in the previous game, press **Y** for Yes. The game will begin again, using the same names. If you want to change any players, press **N** for No, and you will be returned to the screen on which you enter the information for the new set of participants.

## Strategies for Winning

Wildcatting is a game of deduction. The color bars shown in the lower left corner of the map indicate the proximity to the oil center. The closest (94% probability) is indicated by a pink land marker and the furthest (25% probability) is indicated by a white land marker. These colors form concentric circles around the oil deposit; therefore, no matter where it is located, the revealed colors help guide you toward the center of the oil field. Every game uses a new map, so there's always a fresh challenge!







### RADIO SHACK SOFTWARE LICENSE

- A.** Radio Shack grants to CUSTOMER a non-exclusive, paid up license to use on CUSTOMER'S computer the Radio Shack computer software received. Title to the media on which the software is recorded (cassette and/or disk) or stored (ROM) is transferred to the CUSTOMER, but not title to the software.
- B.** In consideration for this license, CUSTOMER shall not reproduce copies of Radio Shack software except to reproduce the number of copies required for use on CUSTOMER'S computer (if the software allows a backup copy to be made), and shall include Radio Shack's copyright notice on all copies of software reproduced in whole or in part.
- C.** CUSTOMER may resell Radio Shack's system and applications software (modified or not, in whole or in part), provided CUSTOMER has purchased one copy of the software for each one resold. The provisions of this software License (paragraphs A, B, and C) shall also be applicable to third parties purchasing such software from CUSTOMER.



## IMPORTANT NOTICE

ALL RADIO SHACK COMPUTER PROGRAMS ARE LICENSED ON AN "AS IS" BASIS WITHOUT WARRANTY.

Radio Shack shall have no liability or responsibility to customer or any other person or entity with respect to any liability, loss or damage caused or alleged to be caused directly or indirectly by computer equipment or programs sold by Radio Shack, including but not limited to any interruption of service, loss of business or anticipatory profits or consequential damages resulting from the use or operation of such computer or computer programs.

RADIO SHACK  A DIVISION OF TANDY CORPORATION

U.S.A.: FORT WORTH, TEXAS 76102  
CANADA: BARRIE, ONTARIO L4M 4W5

---

TANDY CORPORATION

AUSTRALIA

280-316 VICTORIA ROAD  
RYDALMERE, N.S.W. 2116

BELGIUM

PARC INDUSTRIEL DE NANINNE  
5140 NANINNE

U. K.

BILSTON ROAD WEDNESBURY  
WEST MIDLANDS WS10 7JN

PRINTED IN U.S.A.